

EST 130	BASICS OF ELECTRICAL AND ELECTRONICS ENGINEERING	CATEGORY	L	T	P	CREDIT	YEAR OF INTRODUCTION
		ESC	4	0	0	4	2019

Preamble:

This course aims to (1) equip the students with an understanding of the fundamental principles of electrical engineering (2) provide an overview of evolution of electronics, and introduce the working principle and examples of fundamental electronic devices and circuits (3) provide an overview of evolution of communication systems, and introduce the basic concepts in radio communication.

Prerequisite: Physics and Mathematics (Pre-university level)

Course Outcomes: After the completion of the course the student will be able to

CO 1	Apply fundamental concepts and circuit laws to solve simple DC electric circuits
CO 2	Develop and solve models of magnetic circuits
CO 3	Apply the fundamental laws of electrical engineering to solve simple ac circuits in steady state
CO 4	Describe working of a voltage amplifier
CO 5	Outline the principle of an electronic instrumentation system
CO 6	Explain the principle of radio and cellular communication

Mapping of course outcomes with program outcomes

	PO 1	PO 2	PO 3	PO 4	PO 5	PO 6	PO 7	PO 8	PO 9	PO 10	PO 11	PO 12
CO 1	3	1	-	-	-	-	-	-	-	-	-	2
CO 2	3	1	-	-	-	-	-	-	-	-	-	2
CO 3	3	1	-	-	-	-	-	-	-	-	-	2
CO 4	2	-	-	-	-	-	-	-	-	-	-	-
CO 5	2	-	-	-	-	-	-	-	-	-	-	2
CO 6	2	-	-	-	-	-	-	-	-	-	-	2

Assessment Pattern

Bloom's Category	Basic Electrical Engineering			Basic Electronics Engineering		
	Continuous Assessment Tests		End Semester Examination (Marks)	Continuous Assessment Tests		End Semester Examination (Marks)
	Test 1 (Marks)	Test 2 (Marks)		Test 1 (Marks)	Test 2 (Marks)	
Remember	0	0	10	10	10	20
Understand	12.5	12.5	20	15	15	30
Apply	12.5	12.5	20			
Analyse						
Evaluate						
Create						

Mark distribution

Total Marks	CIE marks	ESE marks	ESE Duration
150	50	100	3 hours

Continuous Internal Evaluation Pattern:

Attendance	: 10 marks
Continuous Assessment Test (2 numbers)	: 25 marks
Assignment/Quiz/Course project	: 15 marks

End Semester Examination Pattern: There will be two parts; Part I – Basic Electrical Engineering and Part II – Basic Electronics Engineering. Part I and PART II carries 50 marks each. For the end semester examination, part I contain 2 parts - Part A and Part B. Part A contain 5 questions carrying 4 marks each (not exceeding 2 questions from each module). Part B contains 2 questions from each module out of which one to be answered. Each question carries 10 mark and can have maximum 2 sub-divisions. The pattern for end semester examination for part II is same as that of part I. **However, student should answer both part I and part 2 in separate answer booklets.**

Course Level Assessment Questions

Course Outcome 1 (CO1):

1. Solve problems based on current division rule.
2. Solve problems with Mesh/node analysis.
3. Solve problems on Wye-Delta Transformation.

Course Outcome 2 (CO2):

1. Problems on series magnetic circuits
2. Problems on parallel magnetic circuits
3. Problems on composite magnetic circuits

4. Course Outcome 3 (CO3):

1. problems on self inductance, mutual inductance and coefficient of coupling
2. problems on rms and average values of periodic waveforms
3. problems on series ac circuits
4. Compare star and Delta connected 3 phase AC systems.

Course Outcome 4 (CO4): Describe working of a voltage amplifier

1. What is the need of voltage divider biasing in an RC coupled amplifier?

2. Define operating point in the context of a BJT amplifier.
3. Why is it required to have a voltage amplifier in a public address system?

Course Outcome 5 (CO5): Outline the principle of an electronic instrumentation system

1. Draw the block diagram of an electronic instrumentation system.
2. What is a transducer?
3. Explain the working principle of operation of digital multimeter.

Course Outcome 6 (CO6): Explain the principle of radio and cellular communication

1. What is the working principle of an antenna when used in a radio transmitter?
2. What is the need of two separate sections RF section and IF section in a super heterodyne receiver?
3. What is meant by a cell in a cellular communication?

Model Question Paper

QP CODE:

Pages: 3

Reg No.: _____

Name: _____

**APJ ABDUL KALAM TECHNOLOGICAL UNIVERSITY FIRST SEMESTER B.TECH DEGREE EXAMINATION,
MONTH & YEAR**

Course Code: EST 130

Course Name: BASICS OF ELECTRICAL AND ELECTRONICS ENGINEERING

Max. Marks: 100

Duration: 3 hours

Answer both part I and part 2 in separate answer booklets

PART I

BASIC ELECTRICAL ENGINEERING

PART A

Answer all questions; each question carries 4 marks.

1. Calculate the current through the 4Ω resistor in the circuit shown, applying current division rule:

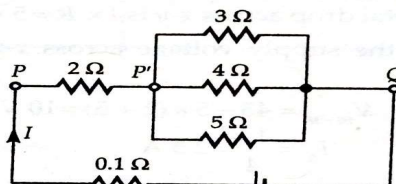

2. Calculate the RMS and average values of a purely sinusoidal current having peak value 15A.
3. An alternating voltage of $(80+j60)V$ is applied to an RX circuit and the current flowing through the circuit is $(-4+j10)A$. Calculate the impedance of the circuit in rectangular and polar forms. Also determine if X is inductive or capacitive.
4. Derive the relation between line and phase values of voltage in a three phase star connected system.
5. Compare electric and magnetic circuits. (5x4=20)

PART B

Answer one question from each module; each question carries 10 marks.

Module 1

6. . Calculate the node voltages in the circuit shown, applying node analysis:

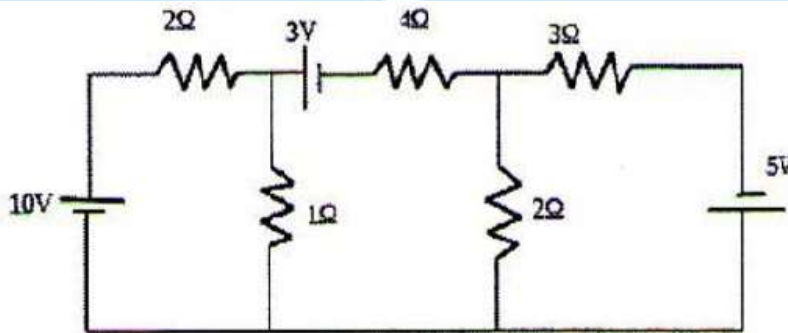

7. (a) State and explain Kirchoff's laws. (4 marks)
- (b) Calculate the current through the galvanometer (G) in the circuit shown:

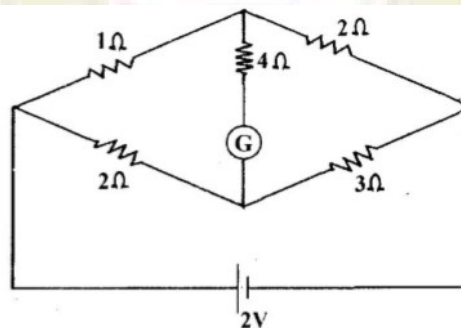

(6 marks)

Module 2

8. (a) State and explain Faraday's laws of electromagnetic induction with examples. (4 marks)
- (b) Differentiate between statically and dynamically induced emf. A conductor of length 0.5m moves in a uniform magnetic field of flux density 1.1T at a velocity of 30m/s. Calculate the emf induced in the conductor if the direction of motion of the conductor is inclined at 60° to the direction of field. (6 marks)
9. (a) Derive the amplitude factor and form factor of a purely sinusoidal waveform. (5 marks)
- (b) A current wave is made up of two components—a 5A dc component and a 50Hz ac component, which is a sinusoidal wave with a peak value of 5A. Sketch the resultant waveform and determine its RMS and average values. (5 marks)

Module 3

10. Draw the power triangle and define active, reactive and apparent powers in ac circuits. Two coils A and B are connected in series across a 240V, 50Hz supply. The resistance of A is 5Ω and the inductance of B is 0.015H. If the input from the supply is 3kW and 2kVAR, find the inductance of A and the resistance of B. Also calculate the voltage across each coil.
11. A balanced three phase load consists of three coils each having resistance of 4Ω and inductance 0.02H. It is connected to a 415V, 50Hz, 3-phase ac supply. Determine the phase voltage, phase current, power factor and active power when the loads are connected in (i) star (ii) delta.

(3x10=30)

PART II

BASIC ELECTRONICS ENGINEERING

PART A

Answer all questions; each question carries 4 marks.

1. Give the specifications of a resistor. The colour bands marked on a resistor are Blue, Grey, Yellow and Gold. What are the minimum and maximum resistance values expected from that resistance?
2. What is meant by avalanche breakdown?
3. Explain the working of a full-wave bridge rectifier.
4. Discuss the role of coupling and bypass capacitors in a single stage RC coupled amplifier.
5. Differentiate AM and FM communication systems.

(5x4=20)

PART B

Answer one question from each module; each question carries 10 marks.

Module 4

6. a) Explain with diagram the principle of operation of an NPN transistor. (5)
b) Sketch and explain the typical input-output characteristics of a BJT when connected in common emitter configuration. (5)

OR

7. a) Explain the formation of a potential barrier in a P-N junction diode. (5)
b) What do you understand by Avalanche breakdown? Draw and explain the V-I characteristics of a P-N junction and Zener diode. (5)

Module 5

8. a) With a neat circuit diagram, explain the working of an RC coupled amplifier. (6)
b) Draw the frequency response characteristics of an RC coupled amplifier and state the reasons for the reduction of gain at lower and higher frequencies. (4)

OR

9. a) With the help of block diagram, explain how an electronic instrumentation system. (6)
b) Explain the principle of an antenna. (4)

Module 6

10. a) With the help of a block diagram, explain the working of Super hetrodyne receiver. (6)
b) Explain the importance of antenna in a communication system. (4)

OR

11. a) With neat sketches explain a cellular communication system. (5)
b) Explain GSM communication with the help of a block diagram. (5)

(3x10=30)

SYLLABUS

MODULE 1: Elementary Concepts of Electric Circuits

Elementary concepts of DC electric circuits: Basic Terminology including voltage, current, power, resistance, emf; Resistances in series and parallel; Current and Voltage Division Rules; Capacitors & Inductors: V-I relations and energy stored. Ohms Law and Kirchhoff's laws-Problems; Star-delta conversion (resistive networks only-derivation not required)-problems.

Analysis of DC electric circuits: Mesh current method - Matrix representation - Solution of network equations. Node voltage methods-matrix representation-solution of network equations by matrix methods. Numerical problems.

MODULE 2: Elementary Concepts of Magnetic circuits, Electromagnetic Induction and AC fundamentals

Magnetic Circuits: Basic Terminology: MMF, field strength, flux density, reluctance - comparison between electric and magnetic circuits- Series and parallel magnetic circuits with composite materials, numerical problems.

Electromagnetic Induction: Faraday's laws, problems, Lenz's law- statically induced and dynamically induced emfs - Self-inductance and mutual inductance, coefficient of coupling

Alternating Current fundamentals: Generation of alternating voltages-Representation of sinusoidal waveforms: frequency, period, Average, RMS values and form factor of waveforms-Numerical Problems.

MODULE 3: AC Circuits

AC Circuits: Phasor representation of sinusoidal quantities. Trigonometric, Rectangular, Polar and complex forms. Analysis of simple AC circuits: Purely resistive, inductive & capacitive circuits; Inductive and capacitive reactance, concept of impedance. Average Power Power factor. Analysis of RL, RC and RLC series circuits-active, reactive and apparent power. Simple numerical problems.

Three phase AC systems: Generation of three phase voltages; advantages of three phase systems, star and delta connections (balanced only), relation between line and phase voltages, line and phase currents- Numerical problems

MODULE 4

Introduction to Semiconductor devices: Evolution of electronics – Vacuum tubes to nano electronics. Resistors, Capacitors and Inductors (constructional features not required): types, specifications. Standard values, color coding. PN Junction diode: Principle of operation, V-I characteristics, principle of avalanche breakdown. Bipolar Junction Transistors: PNP and NPN structures, Principle of operation, relation between current gains in CE, CB and CC, input and output characteristics of common emitter configuration.

MODULE 5

Basic electronic circuits and instrumentation: Rectifiers and power supplies: Block diagram description of a dc power supply, Working of a full wave bridge rectifier, capacitor filter (no analysis), working of simple zener voltage regulator. Amplifiers: Block diagram of Public Address system, Circuit diagram and working of common emitter (RC coupled) amplifier with its frequency response, Concept of voltage divider biasing. Electronic Instrumentation: Block diagram of an electronic instrumentation system.

MODULE 6

Introduction to Communication Systems: Evolution of communication systems – Telegraphy to 5G. Radio communication: principle of AM & FM, frequency bands used for various communication systems, block diagram of super heterodyne receiver, Principle of antenna – radiation from accelerated charge. Mobile communication: basic principles of cellular communications, principle and block diagram of GSM.

Text Books

1. D P Kothari and I J Nagrath, "Basic Electrical Engineering", Tata McGraw Hill, 2010.
2. D C Kulshreshtha, "Basic Electrical Engineering", Tata McGraw Hill, 2010.
3. ChinmoySaha, Arindham Halder and Debarati Ganguly, Basic Electronics - Principles and Applications, Cambridge University Press, 2018.
4. M.S.Sukhija and T.K.Nagsarkar, Basic Electrical and Electronics Engineering, Oxford University Press, 2012.
5. Wayne Tomasi and Neil Storey, A Textbook On Basic Communication and Information Engineering, Pearson, 2010.

Reference Books

1. Del Toro V, "Electrical Engineering Fundamentals", Pearson Education.
2. T. K. Nagsarkar, M. S. Sukhija, "Basic Electrical Engineering", Oxford Higher Education.
3. Hayt W H, Kemmerly J E, and Durbin S M, "Engineering Circuit Analysis", Tata McGraw-Hill
4. Hughes, "Electrical and Electronic Technology", Pearson Education.
5. V. N. Mittle and Arvind Mittal, "Basic Electrical Engineering," Second Edition, McGraw Hill.
6. Parker and Smith, "Problems in Electrical Engineering", CBS Publishers and Distributors.
7. S. B. Lal Seksena and Kaustuv Dasgupta, "Fundamentals of Electrical Engineering", Cambridge University Press.
8. Anant Agarwal, Jeffrey Lang, Foundations of Analog and Digital Electronic Circuits, Morgan Kaufmann Publishers, 2005.
9. Bernard Grob, Basic Electronics, McGraw Hill.
10. A. Bruce Carlson, Paul B. Crilly, Communication Systems: An Introduction to Signals and Noise in Electrical Communication, Tata McGraw Hill, 5th Edition.

COURSE CONTENTS AND LECTURE SCHEDULE

No	Topic	No. of Lectures
1	<i>Elementary Concepts of Electric Circuits</i>	
1.1	<p>Elementary concepts of DC electric circuits:</p> <p>Basic Terminology including voltage, current, power, resistance, emf; Resistances in series and parallel; Current and Voltage Division Rules; Capacitors & Inductors: V-I relations and energy stored.</p> <p>Ohms Law and Kirchhoff's laws-Problems;</p> <p>Star-delta conversion (resistive networks only-derivation not required)-problems.</p>	1 2 1
1.2	<p>Analysis of DC electric circuits: Mesh current method - Matrix representation - Solution of network equations.</p> <p>Node voltage methods-matrix representation-solution of network equations by matrix methods.</p> <p>Numerical problems.</p>	1 1 2
2	Elementary Concepts of Magnetic circuits, Electromagnetic Induction and AC fundamentals	
2.1	<p>Magnetic Circuits: Basic Terminology: MMF, field strength, flux density, reluctance - comparison between electric and magnetic circuits-</p> <p>Series and parallel magnetic circuits with composite materials, numerical problems.</p>	1 2
2.2	<p>Electromagnetic Induction: Faraday's laws, problems, Lenz's law-statically induced and dynamically induced emfs -</p> <p>Self-inductance and mutual inductance, coefficient of coupling</p>	1 2
2.3	<p>Alternating Current fundamentals: Generation of alternating voltages-Representation of sinusoidal waveforms: frequency, period, Average, RMS values and form factor of waveforms-Numerical Problems.</p>	2
3	AC Circuits	

3.1	<p>AC Circuits: Phasor representation of sinusoidal quantities. Trigonometric, Rectangular, Polar and complex forms.</p> <p>Analysis of simple AC circuits: Purely resistive, inductive & capacitive circuits; Inductive and capacitive reactance, concept of impedance. Average Power, Power factor.</p> <p>Analysis of RL, RC and RLC series circuits-active, reactive and apparent power.</p> <p>Simple numerical problems.</p>	1 2 1 2
3.2	<p>Three phase AC systems: Generation of three phase voltages; advantages of three phase systems, star and delta connections (balanced only), relation between line and phase voltages, line and phase currents- Numerical problems.</p>	2
4	Introduction to Semiconductor devices	
4.1	Evolution of electronics – Vacuum tubes to nano electronics (In evolutionary perspective only)	1
4.2	Resistors, Capacitors and Inductors: types, specifications. Standard values, color coding (No constructional features)	2
4.3	PN Junction diode: Principle of operation, V-I characteristics, principle of avalanche breakdown	2
4.4	Bipolar Junction Transistors: PNP and NPN structures, Principle of operation, relation between current gains in CE, CB and CC, input and output characteristics of common emitter configuration	3
5	Basic electronic circuits and instrumentation	
5.1	Rectifiers and power supplies: Block diagram description of a dc power supply, Working of a full wave bridge rectifier, capacitor filter (no analysis), working of simple zener voltage regulator	3
5.2	Amplifiers: Block diagram of Public Address system, Circuit diagram and working of common emitter (RC coupled) amplifier with its frequency response, Concept of voltage divider biasing	4
5.3	Electronic Instrumentation: Block diagram of an electronic instrumentation system	2
6	Introduction to Communication Systems	
6.1	Evolution of communication systems – Telegraphy to 5G	1

6.2	Radio communication: principle of AM & FM, frequency bands used for various communication systems, block diagram of super heterodyne receiver, Principle of antenna – radiation from accelerated charge	4
6.3	Mobile communication: basic principles of cellular communications, principle and block diagram of GSM.	2

Suggested Simulation Assignments for Basic Electronics Engineering

1. Plot V-I characteristics of Si and Ge diodes on a simulator
2. Plot Input and Output characteristics of BJT on a simulator
3. Implementation of half wave and full wave rectifiers
4. Simulation of RC coupled amplifier with the design supplied
5. Generation of AM signal

Note: The simulations can be done on open tools such as QUCS, KiCad, GNURadio or similar software to augment the understanding.